

THIS DRAWING IS UNPUBLISHED. RELEASED FOR PUBLICATION  
 © COPYRIGHT BY TYCO ELECTRONICS CORPORATION. ALL RIGHTS RESERVED.

LOC	DIST	REVISIONS			
P	LTR	DESCRIPTION	DATE	DWN	APVD
G	86	H4	REV PER ECR 07-028435	27NOV07	JR TM

- 1 STAMP " AMP 18-16"
- 2 FOR 1.40 TO 3.43 [.055 TO .135] WIRE INSULATION DIA.
- 3 TONGUE MATERIAL THK: 0.79±0.05 [.031±.002]
- △4 BODY: MATERIAL: COPPER ASTM B152  
FINISH: GOLD PL. PER ASTM B488, TYPE 2 GRADE C, 0.00254 [.000100] MIN EXT THK OVER NICKEL PER (QQ-N-290) 0.00076 [.000030] EXT. THK.
- △5 SLEEVE: MATERIAL: COPPER ASTM B152  
FINISH: NICKEL PL. (QQ-N-290) 0.00076 [.000030] AVG EXT THK.
- △6 INSULATION: MATERIAL: TEFLON (ASTM D3295)  
COLOR: ORANGE

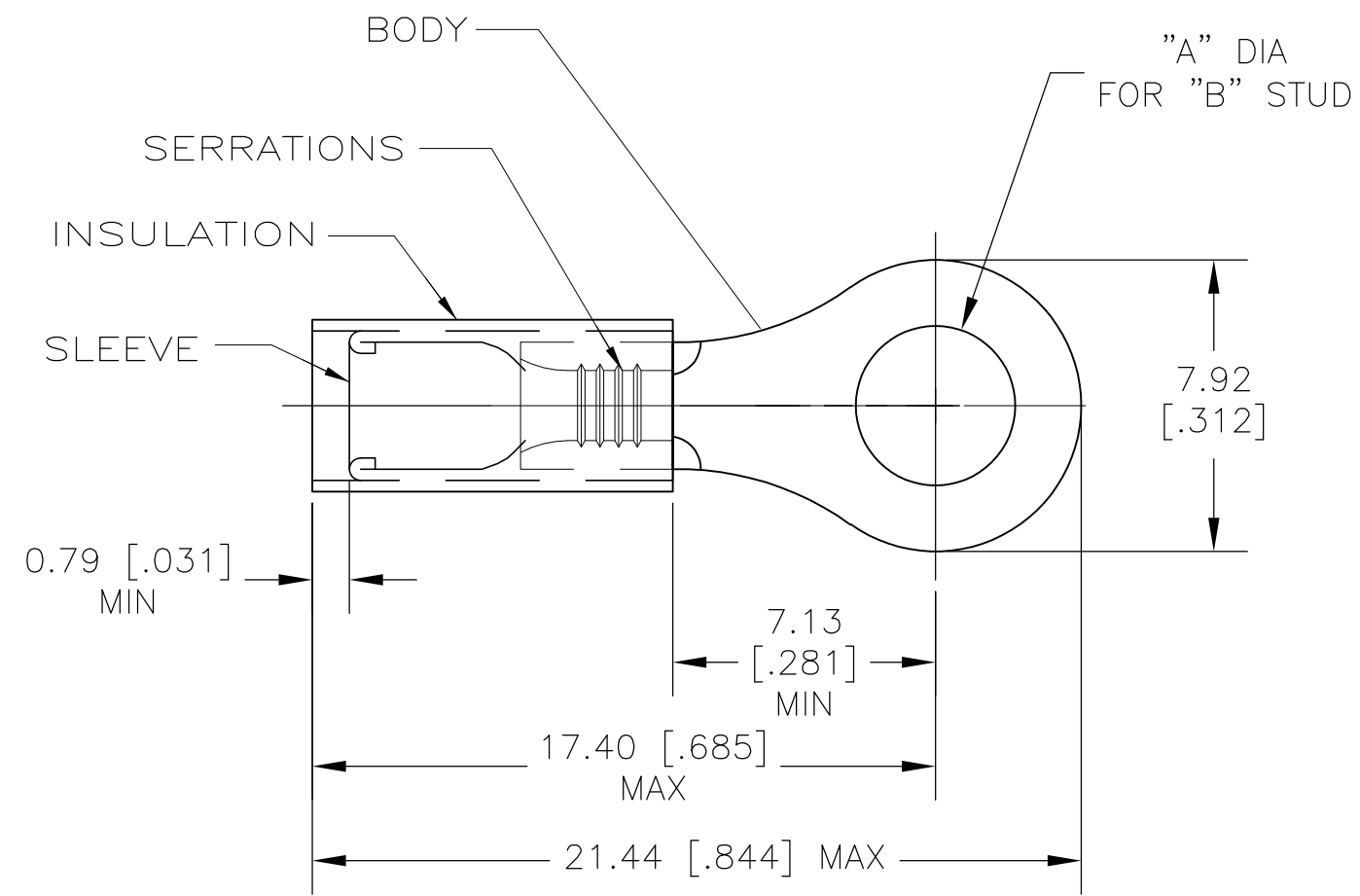

#10	5.00±0.08 [.197±.003]	1-332454-0
#8	4.34±0.08 [.171±.003]	332454
"B"	"A"	PART NO.

<b>AMP INCORPORATED</b> <b>CUSTOMER SERVICE SYSTEMS</b>		MAX RECOMMENDED OPERATING TEMPERATURE: 260°C	THIS DRAWING IS A CONTROLLED DOCUMENT.		DWN JR RUTH 11jul05 CHK T MICHIELUTTI 11JUL05 APVD T MICHIELUTTI 11JUL05 PRODUCT SPEC APPLICATION SPEC WEIGHT -	<b>Tyco Electronics</b> Tyco Electronics Corporation Harrisburg, Pa 17105-3608		
FOR ADDITIONAL PRODUCT INFORMATION OR COPIES OF DRAWINGS AND TECHNICAL DOCUMENTS PRODUCT INFORMATION CENTER 1-800-522-6752	FOR APPLICATION TOOLING ASSISTANCE CENTER TOOLING INFORMATION 1-800-722-1111	VOLTAGE RATING: 300V MAX	DIMENSIONS: INCHES	TOLERANCES UNLESS OTHERWISE SPECIFIED: 0 PLC ± - 1 PLC ± - 2 PLC ± 0.20[.008] 3 PLC ± - 4 PLC ± - ANGLES ± -	NAME TERMINAL, PIDG , STRATO-THERM, RING TONGUE, WIRE SIZE: 18-16			RESTRICTED TO -
FOR ORDER ENTRY 1-800-526-5142	THIS DRAWING IS A CONTROLLED DOCUMENT FOR AMP INCORPORATED. IT IS SUBJECT TO CHANGE AND THE CONTROLLING ENGINEERING ORGANIZATION SHOULD BE CONTACTED FOR THE LATEST REVISION.		MATERIAL △4 △5 △6	FINISH △4 △5 △6	SIZE A3 CAGE CODE 00779 DRAWING NO C-332454	SCALE 5:1 SHEET 1 OF 1 REV H4		